

# PORTABLE VACUUM SYSTEM

Users Manual



624 South B Street • Tustin, CA 92780  
[advantageman.com](http://advantageman.com)



**ADVANTAGE**  
MANUFACTURING



**ADVANTAGE**  
MANUFACTURING

Thank you for purchasing the Advantage Portable Vacuum System. We recommend that you take a few minutes to read this owner's manual and familiarize yourself with the proper operation of your system.

Thank you for your purchase and enjoy your vacuum system.

### Contents



Introduction .....	1
Vacuum System Diagram .....	2
Use of Vacuum System.....	3
Pump Diagram .....	4
Filter Diagram .....	5
Troubleshooting.....	6

Warranty located on back cover

# Vacuum System Diagram



# Operating Instructions

1. Place unit at side of pool.
  2. Make sure ON/OFF switch is set on OFF.
  3. Make sure GFCI is reset.
  4. Plug unit into 20 amp GFCI outlet
  5. Attach discharge hose to outlet side of filter and make sure the union barb is tight with original O-ring in place and place discharge hose into pool.
  6. Open bleeder valve at top of filter to purge air from tank.
  7. Fill hair and lint trap with water and retighten lid.
  8. Flood the suction hose by holding completely under water, then place hand over suction hose to keep water in the hose while attaching to the side union barb (make sure union barb is tight with original O-ring in place). May use optional union check valve.
  9. Start unit by turning the ON/OFF switch to ON position.
  10. Once unit starts to prime watch air relief valve on top of filter. When water comes out of the air relief valve - all air has been purged from the filter. Retighten air relief valve and allow a 1 -2 minutes for the pump to prime.
  11. Vacuum as needed.
  12. If unit does not prime redo steps 1-9.
  13. **Turn off all power and disconnect the unit from the power source before any service is performed.**
  14. Any questions may be answered by calling the Technician live at 1-800-636-8866.
- \*When using standard flex vacuum hose it is advisable to remove the white plastic cuff from the vacuum hose. The cuffs are designed to be used in a skimmer, under water, and will draw in air on the suction side causing priming issues and loss of water flow to the vacuum system.



**Hazardous voltage.  
Can shock, burn, or  
cause death.**  
Disconnect power  
before working on  
pump or motor.

# Pump Assembly Diagram

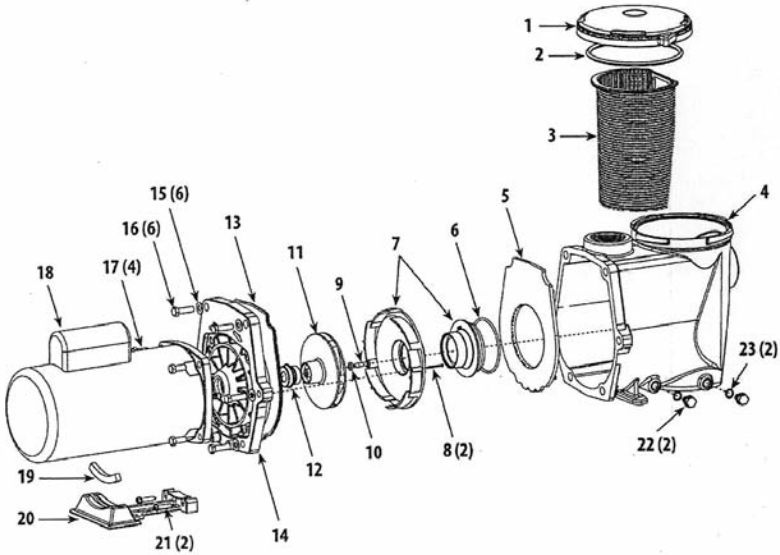

## Item Part Description

- 1 Trap Lid
- 2 Trap Lid O-Ring
- 3 Basket
- 4 Pump Housing
- 5 Diffuser Plate
- 6 Diffuser O-Ring
- 7 Diffuser Assembly
- 8 Diffuser Bolt
- 9 Left Hand Screw
- 10 Gasket Left Hand Screw
- 11 Champion Impeller 1.5HP
- 12 Pump Seal Set
- 13 Seal Plate Gasket

## Item Part Description

- 14 Seal Plate
- 15 3/8" Washer
- 16 3/8" - 16 x 1-1/4" Bolt
- 17 3/8" - 16 x 7/8"
- 18 Motor 1.5HP
- 19 Motor Support Strip
- 20 Motor Support Base
- 21 Hex Screw 1/4" x 1-1/4"
- 22 Drain Plug O-ring
- 23 3/8" Drain Plug

# Filter Assembly Diagram

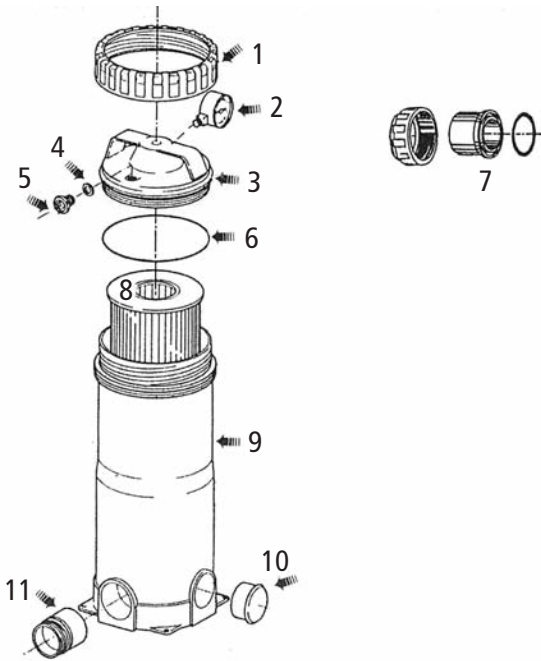

Item	Part	Description
1	205101	Lock Ring
2	205102	Guage
3	205103	Filter Head
4	205104	O-Ring for Bleed Plug
5	205105	Bleed Plug
6	205106	O-Ring for Filter Head
7	UF5010A	1-1/2" Female Slip Union
8	ELE150	150 sq.ft. Filter Element
9	205109	150 sq.ft. Filter
10	205111	Plug
11	UF5050	2" Male Slip x 1-1/2" Union Thread
12	205003	Bleed Pipe 1/2" Diameter

# Troubleshooting



## **MOTOR WILL NOT START**

1. Check Circuit Breakers
2. Check for incorrect or loose wire connections.
3. Make sure the correct power supply is being used.
4. Any on/off switch or pneumatic switch should be in the "on" mode.

## **MOTOR OVERHEATING AND CYCLING ON AND OFF**

1. Check for incorrect or loose wire connections.
2. Check for low voltage supply (frequently caused by undersized wire).
3. Make sure the motor gets a fresh air supply and the vents are kept unclogged.

## **MOTOR MAKES HUMMING NOISE BUT WILL NOT START**

1. Make sure motor shaft turns free.
2. Check for jammed impeller or an obstruction in casing.
3. Check for low voltage and undersized wire.

## **PUMP WILL NOT PRIME**

1. Make sure pump is installed at the proper level and the plumbing lines have been correctly installed to allow the water to enter pump freely.
2. Open air control valves to release any possible air lock.
3. Make sure all suction and discharge lines are clear and unobstructed and all valves are opened.
4. Check for air leaks in the suction line.
5. Remove white cuff from flex hose.

## **LOW WATER FLOW**

1. Check filter pressure gauge, filter may need cleaning.
2. Check for clogged plumbing lines.
3. Check for worn or damaged impeller.
4. Check for low voltage.

## **WATER LEAKS**

1. Check contamination or damage to shaft rotary seal. Replace if necessary.
2. Check compression fitting (union connectors), make sure they are properly aligned and secured. Hand tighten only. Do not use tools.
3. Make sure the O-ring is properly sealed and not damaged.

## **NOISES**

1. Check plumbing vibration – make sure lines are adequately supported.
2. Check for cavitation, due to obstruction in or undersized suction line.

# 1 Year Limited Warranty

Call 800.636.8866 for info on  
Extended Warranty Plans starting at \$29  
for an additional year



**ADVANTAGE**  
MANUFACTURING

**CLAIMS:** All Freight Damage claims must be made within ten (10) calendar days after receipt of the merchandise. If any shipment is received in a damaged condition, your claim must be filed with the delivering carrier and noted on the freight bill before you accept the merchandise.

**RETURNS:** All returns are subject to our written approval and must be accompanied by a "Return Goods Authorization" number obtained from Advantage Manufacturing (ADM) prior to shipment. Unauthorized returns will not be accepted. Freight must be prepaid. Material returned for credit, if in original condition and resaleable, is subject to a 20% handling charge.

**TAXES:** Any Federal or State Excise or Sales Tax for which ADM may be liable on any sale will be charged to and paid by the buyer. Buyer is responsible for furnishing a resale certificate.

**PRICES:** Prices and Products are subject to change without notice.

**LIMITED WARRANTY:** To Buyer, as original purchaser of the Goods, ADM warrants its products free from defects in materials and workmanship for a period of one year from the date of purchase. Parts which fail or become defective during the warranty period, except as a result of freezing, negligence, improper installation, use or care, shall be repaired or replaced, at our option, within ninety (90) calendar days of the receipt of the defective product, barring unforeseen delays. To obtain warranty, replacements or repair, defective components or parts should be returned, transportation paid, to the place of purchase. No returns may be made directly to the factory without the express written authorization of ADM. Pump housing/strainers which become defective during the warranty period, except as a result of freezing, negligence, improper installation, use or care, or as the result of use in association with an automatic valving system, shall be repaired or replaced, at ADM's option, without charge. All other conditions and terms of the standard warranty apply. ADM shall not be responsible for cartage, removal and/or reinstallation labor or any other cost incurred in obtaining warranty replacements. The foregoing warranty does not apply to components manufactured by others. For such products, the warranty established by the respective manufacturers will apply. Shaft Seal failure not covered under warranty.

**LIMITATION ON IMPLIED WARRANTIES:** Implied warranties, including any warranty or merchantability imposed on the sale of the goods under state law, are limited to one year duration for the goods or any parts.

**LIMITATIONS OF LIABILITY:** THE ESSENTIAL PURPOSE OF THIS PROVISION IS TO LIMIT ADM'S LIABILITY HEREUNDER. EXCEPT FOR BODILY INJURY OR DEATH OF A PERSON, UNDER NO CIRCUMSTANCES WILL ADM, ITS EMPLOYEES, OFFICERS OR DIRECTORS, AGENTS, SUCCESSORS OR ASSIGNS, BE LIABLE TO ANYONE UNDER ANY PRODUCT ORDER, SCHEDULE OR TERMS AND CONDITIONS HEREIN, UNDER ANY CONTRACT, STRICT LIABILITY, TORT (INCLUDING NEGLIGENCE) OR OTHER LEGAL OR EQUITABLE THEORY, WHETHER OR NOT FORESEEABLE OR FORESEEN, FOR: (1) BUSINESS INTERRUPTION COSTS, COST OF REWORK, RETESTING, PROCUREMENT OF SUBSTITUTE GOODS, REMOVAL AND REINSTALLATION OF GOODS; OR (2) ANY SPECIAL, INCIDENTAL, EXEMPLARY, INDIRECT OR CONSEQUENTIAL DAMAGES, INCLUDING WITHOUT LIMITATION LOST PROFITS, LITIGATION COSTS, LOSS OF EQUIPMENT, PRODUCTION OR PROFIT, GOODWILL, LOSS OF REVENUE, OR LOSS OF UNITS; COST OF RENTING REPLACEMENTS, AND OTHER ADDITIONAL EXPENSES, EVEN IF THE COMPANY HAS BEEN ADVISED OF THE POSSIBILITY OF SUCH DAMAGES, THERE IS A TOTAL AND FUNDAMENTAL BREACH OF THIS AGREEMENT OR WHETHER ANY REMEDY PROVIDED HEREIN FAILS OF ITS ESSENTIAL PURPOSE. ADM'S LIABILITY AND BUYER'S SOLE REMEDY, WHETHER IN CONTRACT, UNDER WARRANTY, IN TORT (INCLUDING NEGLIGENCE,) IN STRICT LIABILITY OR OTHERWISE, SHALL NOT EXCEED THE RETURN OF THE AMOUNT OF THE PURCHASE PRICE PAID BY BUYER AND SHIPMENT COSTS.

**INDEMNIFICATION:** Buyer will defend and indemnify ADM and its directors, employees, agents, customers, end users, successors and assigns from and against all actual and alleged claims, liabilities, suits, damages, losses and expenses (including attorney's fees and legal costs) arising from, or caused in whole or in part, by buyers breach of any provision, term or condition of purchase.

**BINDING EFFECT:** All sales transactions are binding on ADM and the buyer and their respective directors, officers, employees, agents, subcontractors, successors and permitted assigns.

**GOVERNING LAW:** All transactions will be interpreted and enforced under the laws of the State of California (including without limitation the Uniform Commercial Code as adopted by the California), without recourse to the conflict of laws provision thereof. In no event will the provisions of the UN Convention of the International Sale of Goods apply to any purchases. ADM and buyer agree that any action or proceeding arising out of or in connection with any sale of product or service, will be brought exclusively to a court of competent jurisdiction in the County of Orange, State of California.

**THE LIMIT OF LIABILITY FOR ANY CLAIMS SHALL NOT EXCEED THE AMOUNT PAID OR PREPAID ON ACCOUNT BY BUYER FOR THE GOODS GIVING RISE TO SUCH CLAIMS. BUYER SHALL BE DEEMED TO ASSUME ALL LIABILITY FOR ANY AND ALL DAMAGES ARISING FROM OR IN CONNECTION WITH THE USE OR MISUSE OF THE GOODS BY BUYER, ITS EMPLOYEES, CUSTOMERS AND OTHERS. SELLER SHALL NOT BE LIABLE FOR AND BUYER AGREES TO INDEMNIFY, DEFEND AND HOLD SELLER HARMLESS FROM ANY CLAIMS BASED ON SELLER'S COMPLIANCE WITH BUYER'S DESIGNS, SPECIFICATIONS OR INSTRUCTIONS, OR MODIFICATION OF ANY GOODS BY PARTIES OTHER THAN SELLER, OR USE IN COMBINATION WITH OTHER PRODUCTS. EACH PARTY RECOGNIZES AND AGREES THAT THE WARRANTY DISCLAIMERS AND LIABILITY AND REMEDY LIMITATIONS HEREIN ARE MATERIAL, BARGAINED FOR BASIS OF ANY ORDER OR CONTRACT AND THAT THEY HAVE BEEN TAKEN INTO ACCOUNT AND REFLECTED IN DETERMINING THE CONSIDERATION TO BE GIVEN BY EACH PARTY UNDER ANY ORDER OR CONTRACT AND IN THE DECISION BY EACH PARTY TO ENTER INTO SUCH ORDER OR CONTRACT.**

Copyright Notices: Polaris® is a registered trademark of Zodiac Pool Care, Inc., Letro® is a registered trademark of Letro Products, Sta-Rite® is a registered trademark of Sta-rite Industries, Hayward® is a registered trademark of Hayward Manufacturing Co., Inc., WhisperFlo® is a registered trademark of Pentair Pool and Spa, Inc., Noryl is a registered trademark of GE Plastics, Northstar™ is a trademark of Hayward Manufacturing Co., Inc., Cal Spas® is a registered trademark of California Acrylic Industries, Inc., Aquaflo® is the registered trademark of LSP Products Group, Inc., Vico® is a registered trademark of Vico Industries, Waterway® is a registered trademark of Waterway Plastics, Advantage Manufacturing™ is trademark of Advantage Manufacturing, Federal Copyright – Advantage Manufacturing® 2013